

LEAVING THE CLASSROOM

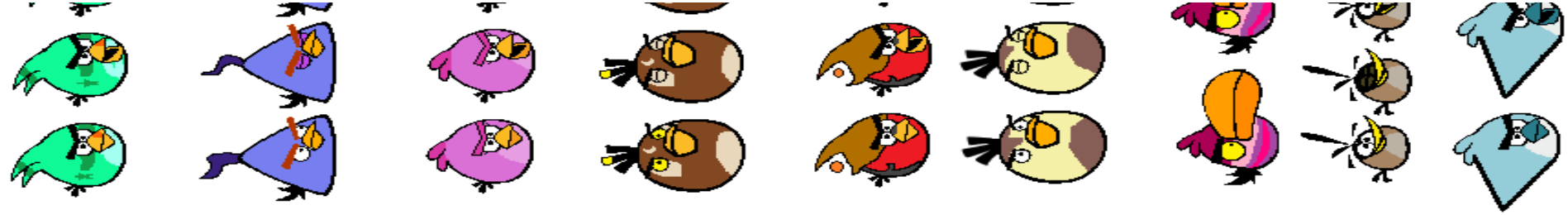

Expected Behaviors

RESPECT - Walk to the Angry Bird line



RESPECT - Carry materials in both hands



RESPECT - Wait to be excused

1.

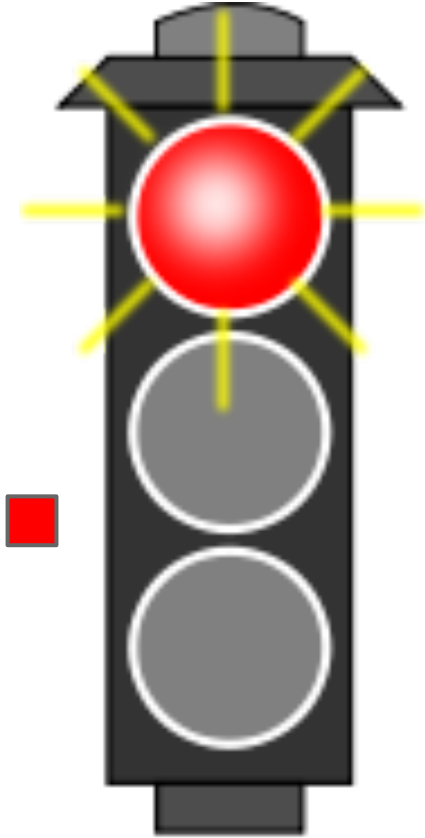

2.

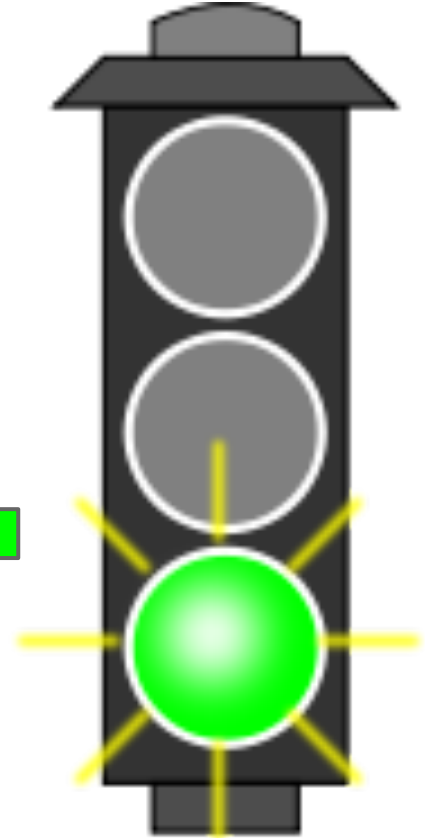

WORK - Voice volume “0”



WORK - Check your mailbox

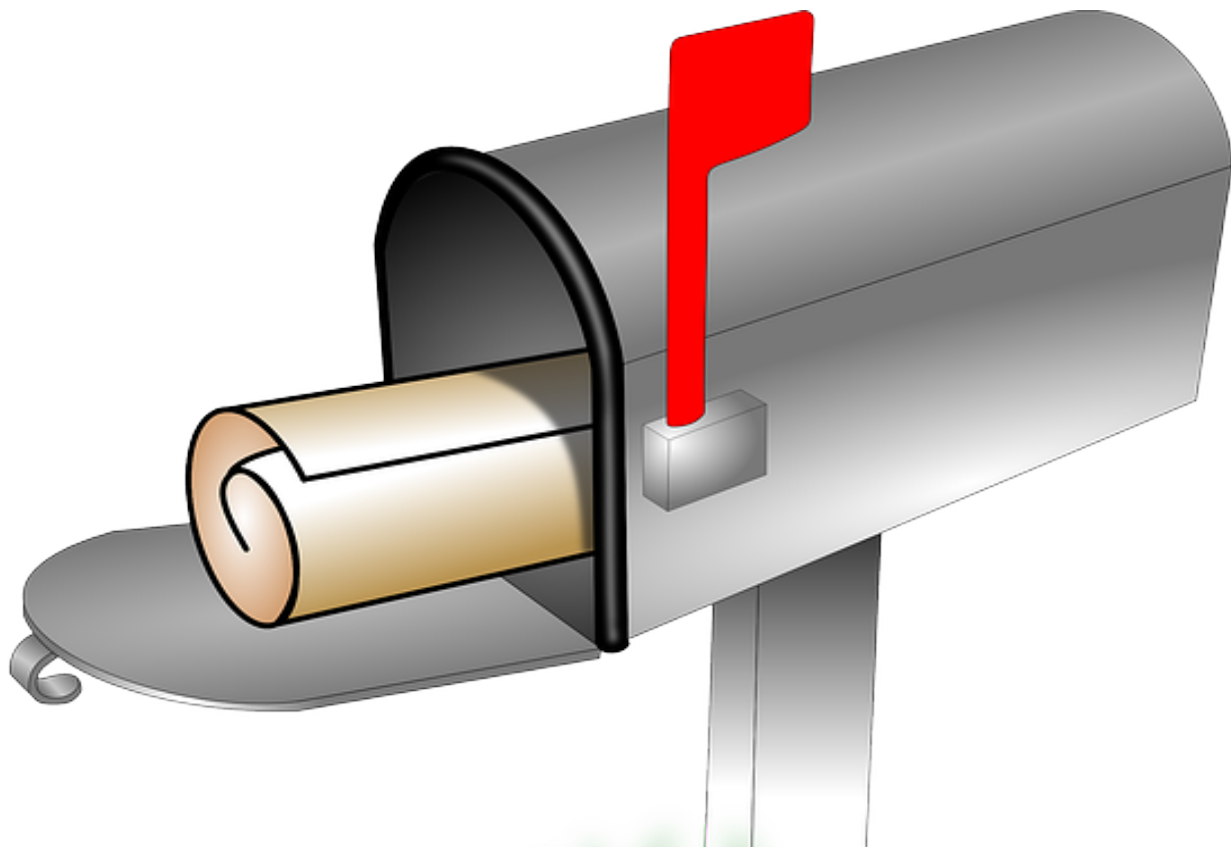

Belong - Stay in line

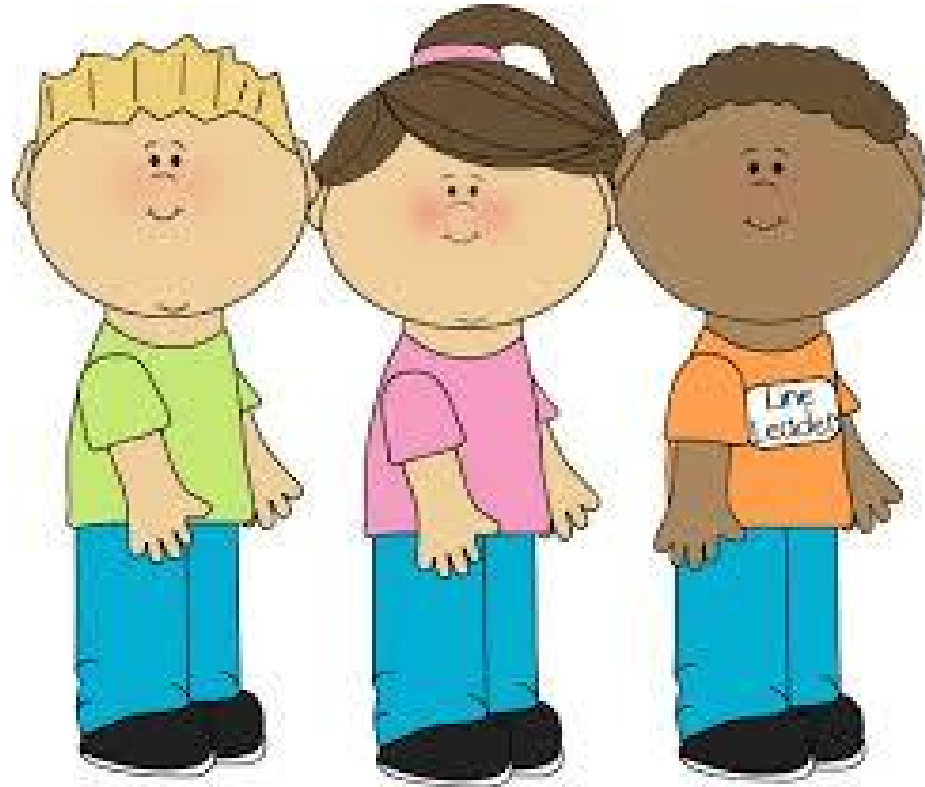

Belong - Franklin waves



BE SAFE- Own Zone

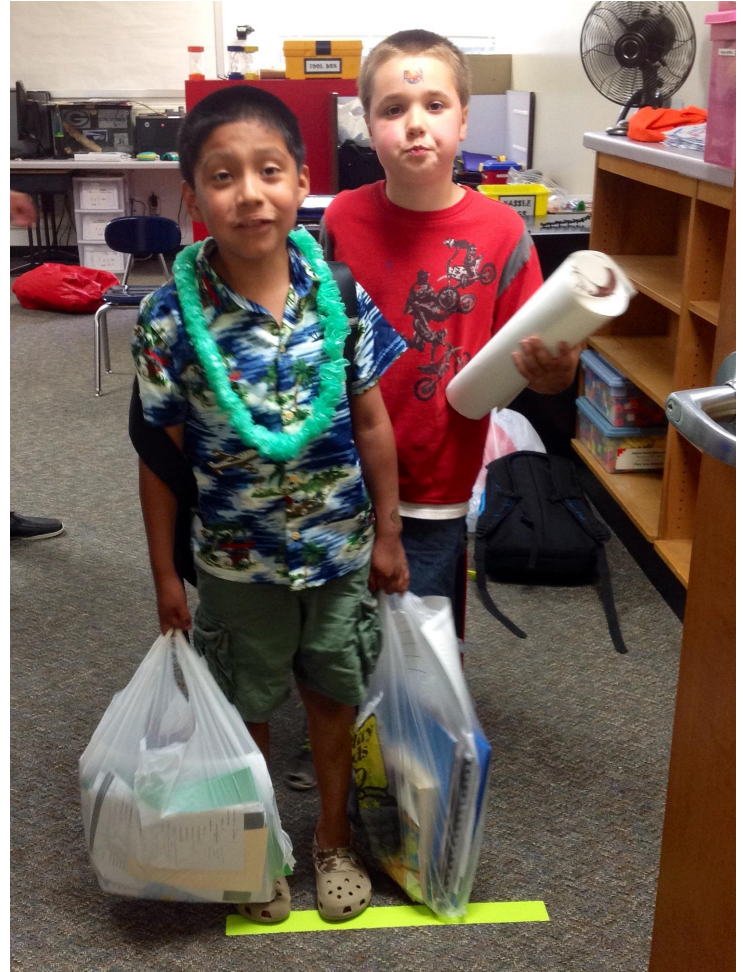

BE SAFE - Feet still while waiting



BE SAFE - One step at a time



A word cloud graphic of the phrase "One step at a time". The words are arranged in a diagonal line from the bottom-left to the top-right. The words "one", "step", "at", "a", "time" are repeated multiple times in a light teal color, with the largest instance of "one" at the bottom-left and the smallest instances at the top-right.

BE SAFE - Eyes forward

